

DOMETIC TURBO DIRECT EXPANSION AIR CONDITIONING SYSTEMS

INSTALLATION MANUAL

Dometic Environmental Corporation

Rev. 20140321

L-2484

DOMETIC TURBO DX AC INSTALLATION MANUAL

CONTENTS

Introduction	4
<hr/>	
Installation	
Safety Considerations (Dangers, Warnings & Cautions)	5
Prior To Installation	5
Installation Overview	5
Blower Rotation	5
Placement of A/C Unit	5
Mounting Brackets	7
Condensate Drain	7
Grills and Transition Boxes	7
Ducting	7
Seawater System	10
Electrical Connections, Grounding and Bonding	14
Installation Checklist and Final Inspection	15

Dometic Turbo A/C Systems

This manual provides proper installation information on the Turbo air conditioning unit (a/c unit). Improper installation procedures can result in unsatisfactory performance and/or premature failure of these a/c units. Before proceeding please read this manual completely. If there are any statements or procedures in this manual that you do not understand, contact the Dometic Environmental Corporation Applications Department for assistance. Phone 954-973-2477 (8 am - 5 pm US Eastern Time), Fax 954-979-4414, or email sales@DometicEnviro.com. Please see the separate control operation manuals for installation of digital or mechanical controls.

Turbo a/c units are covered under the existing Dometic Environmental Corporation (Dometic) warranty policy contained in the corresponding control manual. In the interest of product improvement, Dometic's specifications and design are subject to change without prior notice.

Dometic Turbo A/C Systems

Very Important Safety Considerations: Never install your air conditioner in the bilge or engine room areas. Ensure that the selected location is sealed from direct access to bilge and/or engine room vapors. Do not terminate condensate drain line within three feet of any outlet of engine or generator exhaust systems, nor in a compartment housing an engine or generator, nor in a bilge, unless the drain is connected properly to a sealed condensate or shower sump pump.

Safety Warning – The a/c unit should never be placed such that it can circulate carbon monoxide, fuel vapors or other noxious fumes into the boat's living spaces. Do not install or operate a self-contained unit in the engine room or near an internal combustion engine. Failure to follow this precaution could result in serious injury or death.

Ignition Protection Warning - Self-contained units do not meet federal requirements for ignition protection. Do not install in spaces containing gasoline engines, tanks, LPG/CPG cylinders, regulators, valves or fuel line fittings. Failure to comply may result in injury or death.

Installation and servicing of this system can be hazardous due to system pressure and electrical components. When working on this equipment, always observe precautions described in the literature, tags and labels attached to the unit. Follow all safety codes. Wear safety glasses and work gloves and place a fire extinguisher close to the work area.

The following is a summary of the labels on the unit:

Danger - Electrical shock hazard. Disconnect voltage at main panel or power source before opening any cover. Failure to comply may result in injury or death.

Warning - This component does not meet federal requirements for ignition protection. Do not install in spaces containing gasoline engines, tanks, LPG/CPG cylinders, regulators, valves or fuel line fittings. Failure to comply may result in injury or death.

Warning - To minimize the hazard of electrical shock and personal injury, this component must be effectively grounded. Refer to the installation guidelines for further information.

Caution - High compressor temperature is normal. Do not touch.

Prior To Installation

Read these instructions completely and then plan all connections which must be made to the a/c unit including ducting, condensate drain line, seawater inlet and outlet hoses, electrical power connection, location of control, and seawater pump placement, to assure easy access for routing and future servicing.

Installation Overview

See Figure 1 for an overview of a typical Turbo a/c system installation.

Blower Rotation

Rotate the blower to the direction which allows the most direct airflow discharge through the ducting. Loosen the adjustment screw on blower mount ring, rotate blower to desired position, and then tighten adjustment screw See Figure 2.

Placement of A/C Unit

IMPORTANT INSTALLATION NOTE: The Turbo condensate base pan is equipped with vibration isolators installed in the bottom of the pan. These isolators are designed to dampen the vibration caused by the operating a/c unit from transferring into the mounted surface. Care must be taken when moving the a/c unit across mounting surfaces as isolators can be damaged. Isolators will not normally pull out of pan, but can turn sideways if dragged and may break if excessive dragging occurs. Unit must be picked up after moving to allow isolator to reset into well or vibration isolation will be ineffective.

The a/c unit must be mounted to a low flat level surface, in bottom of locker, under a bunk or dinette seat, or in a similar location. Read the safety considerations above and see Figure 1 before mounting unit.

Dometic Turbo A/C Systems

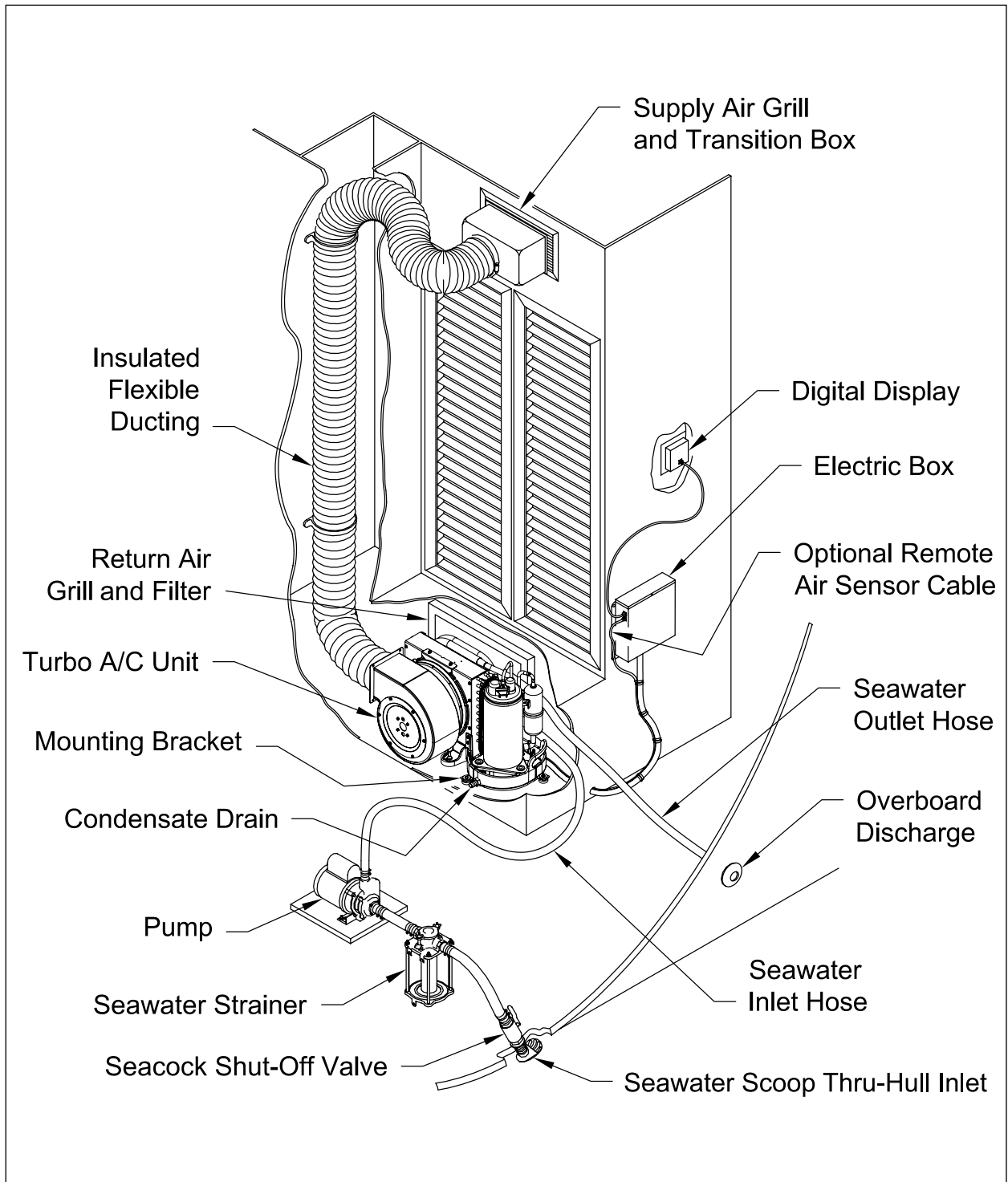

FIGURE 1. Installation overview

Dometic Turbo A/C Systems

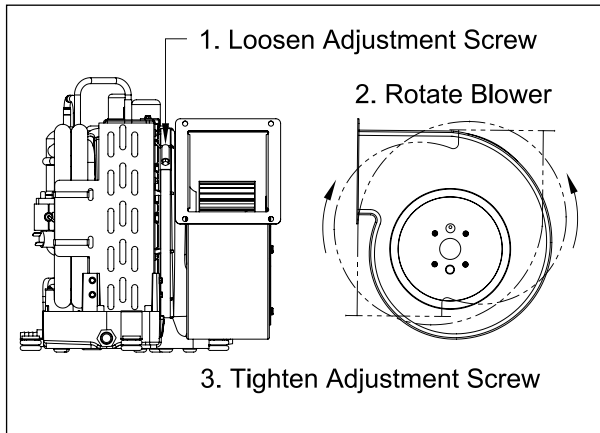

FIGURE 2. Blower rotation

Mount unit with condenser/evaporator coil directly behind return air grill or with at least 3" (76mm) of air circulation clearance if adjacent to a bulkhead or other obstructions. See Figure 3. Compressor should be mounted away from return air grill if possible to minimize sound level in cabin.

Mounting Brackets

The four mounting brackets provided should be placed around edge of drain pan as equally spaced as possible. Secure a/c unit to a flat level mounting surface. Brackets with vibration isolators and sleeves are provided. Customer is to supply screw or bolts. See Figure 4.

Condensate Drain

For installation of the condensate drain please see Figure 4 and follow these instructions:

1. Remove the aft-most-facing drain pan slug (knock-out) from the drain pan. To do this, use the supplied fitting by inserting the hose barb side into the drain hole and, with one quick strike of a rubber mallet, knock out the slug. Remove slug from pan.
2. Screw supplied 1/2" (12.7mm) NPT PVC hose barb into the threaded drain hole and tighten it securely.
3. Attach reinforced 5/8" (15.9mm) I.D. hose to the hose barb and secure it with a stainless steel hose clamp.

4. Route condensate drain hose to a sealed condensate or shower sump pump (see note below).

5. Drain hose must be routed downward to allow water to flow via gravity downhill.

Very Important! Do not terminate condensate drain line within 3' (.91M) of any outlet of engine or generator exhaust systems, nor in a compartment housing an engine or generator, nor in a bilge, unless the drain is connected properly to a sealed condensate or shower sump pump. If drain line is not properly installed, then dangerous fumes may travel up drain line and contaminate living quarters.

Air Filters

Air filters are necessary to remove air borne particulates from the cabin air and to keep the evaporator coil clean. One, and only one, air filter must be installed for each air conditioner unit. Install the air filter either on the a/c unit or in the return air (RA) grill. The a/c unit air filter mounts in the slots in front of the evaporator coil (behind the condenser coil). Or, the return air filter attaches to the back of the RA grill. Clean the air filters regularly per instructions in Owner's Control Manual.

Grills and Transition Boxes

Install the supply air grill as high as possible in a location that will provide uniform air distribution throughout the cabin; grill louvers should be directed upward. The return air grill should be installed as low and close to the a/c unit as possible to insure direct uninterrupted airflow to the evaporator. The return air grill should have a minimum four inches 4" (101.6mm) of air circulation clearance in front of it, free from any furniture or other obstructions. See Figure 3.

In no instance should a supply air discharge be directed towards a return air grill, as this will cause the system to short cycle. Allow for adequate clearance behind the supply air grill(s) for the transition box and ducting connection. See Figure 5 for minimum grill sizes.

Ducting

Good airflow is critical for the performance of the entire system. It is highly dependent on the quality of the ducting installation. The ducting should be run

Dometic Turbo A/C Systems

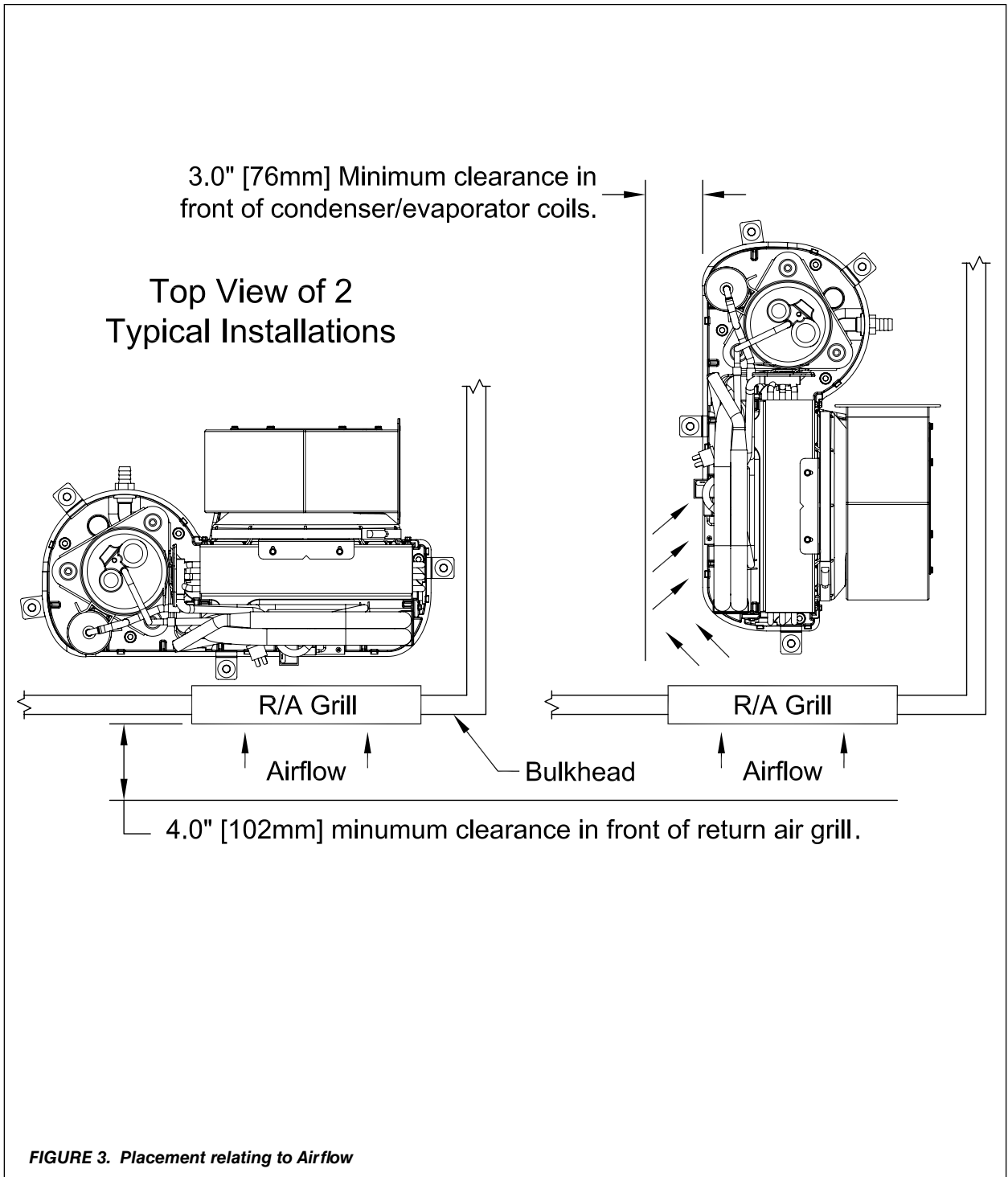

Dometic Turbo A/C Systems

Typical Placement of
Mounting Brackets & Condensate Drains

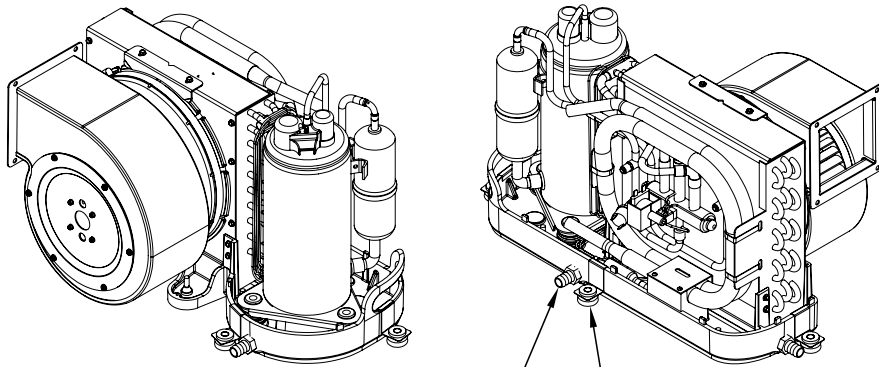

Condensate Drain Pan Hose Barb (1)
Install hose barb in the vessel's aft-facing
direction in one of the three positions shown.

Mounting Brackets (typical 4)
Install one bracket on each side of
drain pan, evenly spaced around pan.

Condensate Drain Installation Detail

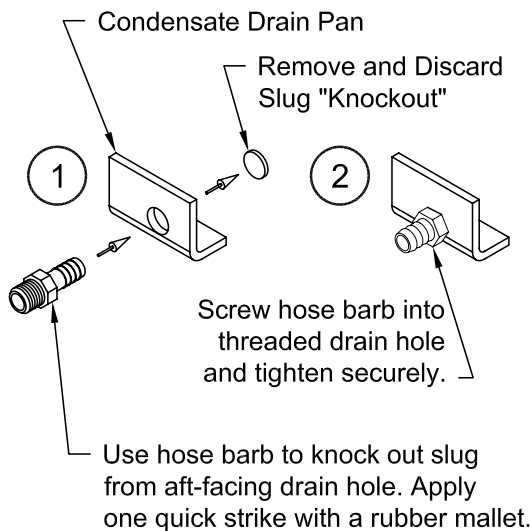

Mounting Bracket Installation Detail

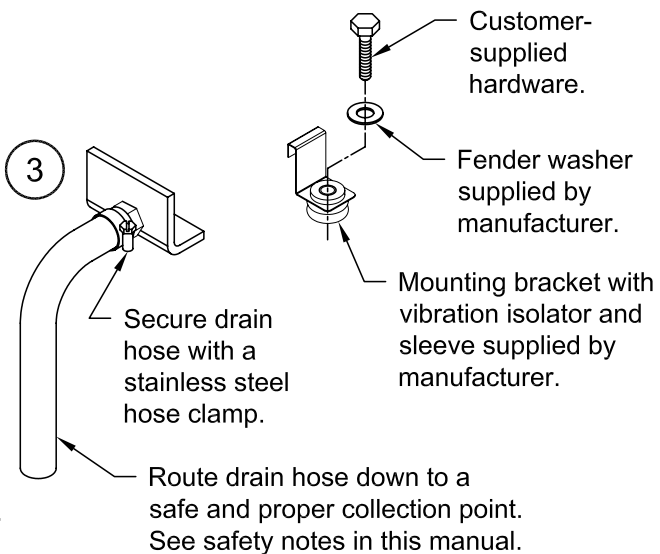

FIGURE 4. Mounting brackets and condensate drain

Dometic Turbo A/C Systems

as straight, smooth and taut as possible minimizing the number of 90° bends (two 90° bends can reduce airflow by 25%). The table in Figure 5 shows minimum duct diameters and their corresponding supply and return air grill minimum areas in square inches. If a transition box is used, the total area of supply air ducts going out of the box should at least equal the area of the supply duct going in to the box.

The following is a summary of proper ducting connections. See Figure 6.

1. Pull back the fiberglass insulation exposing the inner mylar duct hose.
2. Slide the mylar duct hose around the mount ring until it bottoms out.
3. Screw 3 or 4 stainless steel sheet metal screws through the duct hose into the transition ring. Make sure to catch the wire in the duct hose with the heads of the screws. Do not use band clamps, as the hose will slide off.
4. Wrap duct tape around the ducting and ring joint to prevent any air leaks.
5. Pull the insulation back up over the mylar to the ring and tape this joint.
6. Remove excess ducting and use the same connection method at the supply air grill.

All ducting should:

- Be appropriately sized for each application.
- Run as smoothly and taut as possible.
- Have as few bends or loops as possible.
- Be securely fastened to prevent sagging during boat operation.
- Have all excess ducting lengths trimmed off.
- Not be flattened or kinked.
- Insulated when located in high heat load areas (hull side, mechanical compartments, etc.).
- Be properly protected against potential damage when routed through open areas.
- Do not route ducting through engine room or any area where it may be exposed to dangerous vapors or exhaust fumes.

Seawater System

Several guidelines should be followed during the installation of the seawater system. If the circulation pump is centrifugal and not self-priming, it must be mounted so that it is always at least one foot below the water line regardless of which tack the vessel is on. Pump may be mounted horizontally or vertically,

Minimum Duct and Grill Sizes

Turbo Model Capacity	6K	8K	10K	12K	14K	16K
Minimum Duct Diameter (in/mm)	4/102	5/127	6/152	6/152	7/178	7/178
Minimum Duct Area (sq in/cm)	12.6/81	19.6/126	28.3/183	28.3/183	38.5/248	38.5/248
Minimum R/A Grill (sq in/cm)	64/413	80/516	100/645	130/839	144/929	160/1032
Minimum S/A Grill (sq in/cm)	32/206	48/310	60/387	70/452	76/490	80/516

FIGURE 5. Minimum duct and grill sizes

Dometic Turbo A/C Systems

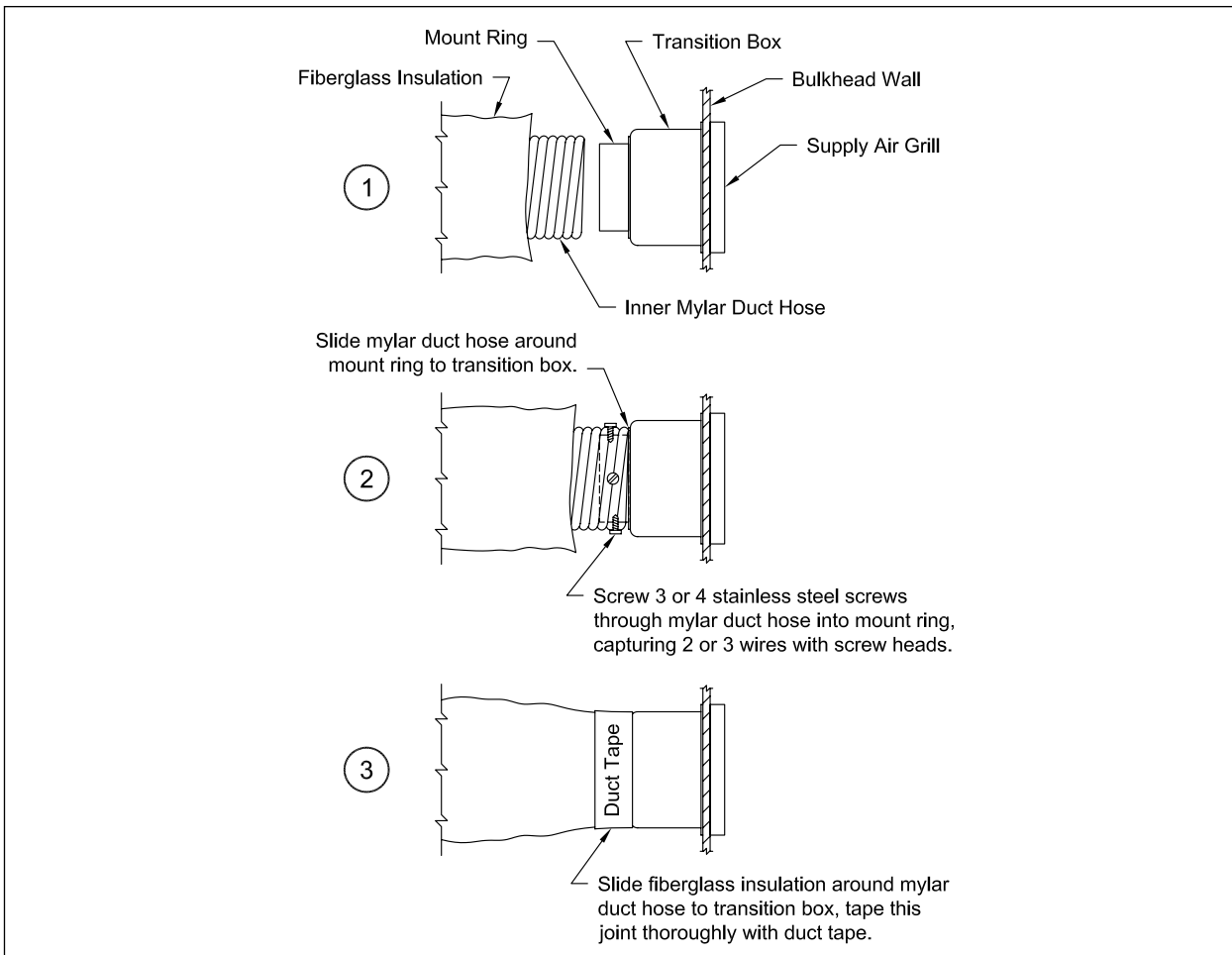

FIGURE 6. Proper ducting connections

however the discharge must always be above the inlet. Pump head should be rotated toward the direction of water flow. See Figure 7.

Install the seawater scoop intake as far below the water line and as close to the keel as possible in any application, but especially on a sailboat. The seawater scoop must remain in the water under all conditions or air will get into the pump. Turn air conditioner off in rough seas. The seawater scoop intake must face forward and not be shared with any other pump.

A seawater strainer is mandatory between the shut off valve (seacock) and the pump to protect the pump

from any foreign matter. Failure to install a seawater strainer will void the pump and unit warranty.

The seawater system should be installed with an upward incline from the seawater scoop and seacock, through the strainer, to the inlet of the pump and then up to the inlet of the a/c unit's condenser coil. The discharge from the a/c unit should then run to the seawater outlet thru-hull fitting which should be located where it can be visually checked for water flow and as close as practicable to the waterline to reduce noise. All hose connections shall be secured by means of two double/reversed stainless steel hose clamps. Use Threaded seal tape on all threaded connections.

Dometic Turbo A/C Systems

The following is a summary of the seawater system installation:

1. Install the seawater scoop thru-hull inlet as close to the keel and as far below the water line as possible, facing forward. Bed the scoop with a marine sealant designed for underwater use.
2. Install a bronze, full flow seacock on the seawater scoop thru-hull inlet.
3. Install a seawater strainer below the level of the pump with access to filter.
4. Mount the pump above the strainer and at least one foot below the waterline.
5. Connect the seacock and strainer with an uphill run of reinforced marine grade hose.
6. Connect the discharge from the pump uphill to the bottom inlet of the a/c unit's condenser coil with 5/8" (15.9mm) reinforced marine grade hose. Connect the discharge from the condenser coil to the over-board discharge thru-hull fitting with 5/8" (15.9mm) reinforced marine grade hose.
7. Avoid loops, high spots or the use of 90° elbows with seawater hose (each 90° elbow is equivalent to 2.5' (0.762M) of hose and a 90° elbow on the pump outlet is equivalent to 20' (61M) of hose.
8. Double clamp all hose connections with two stainless steel clamps, reversing the clamps.
9. Use Threaded seal tape on all threaded connections.
10. Connect all metallic parts in contact with seawater to the vessel's bonding system including the speed scoop inlet, strainer, pump and the air conditioner.

Dometic Turbo A/C Systems

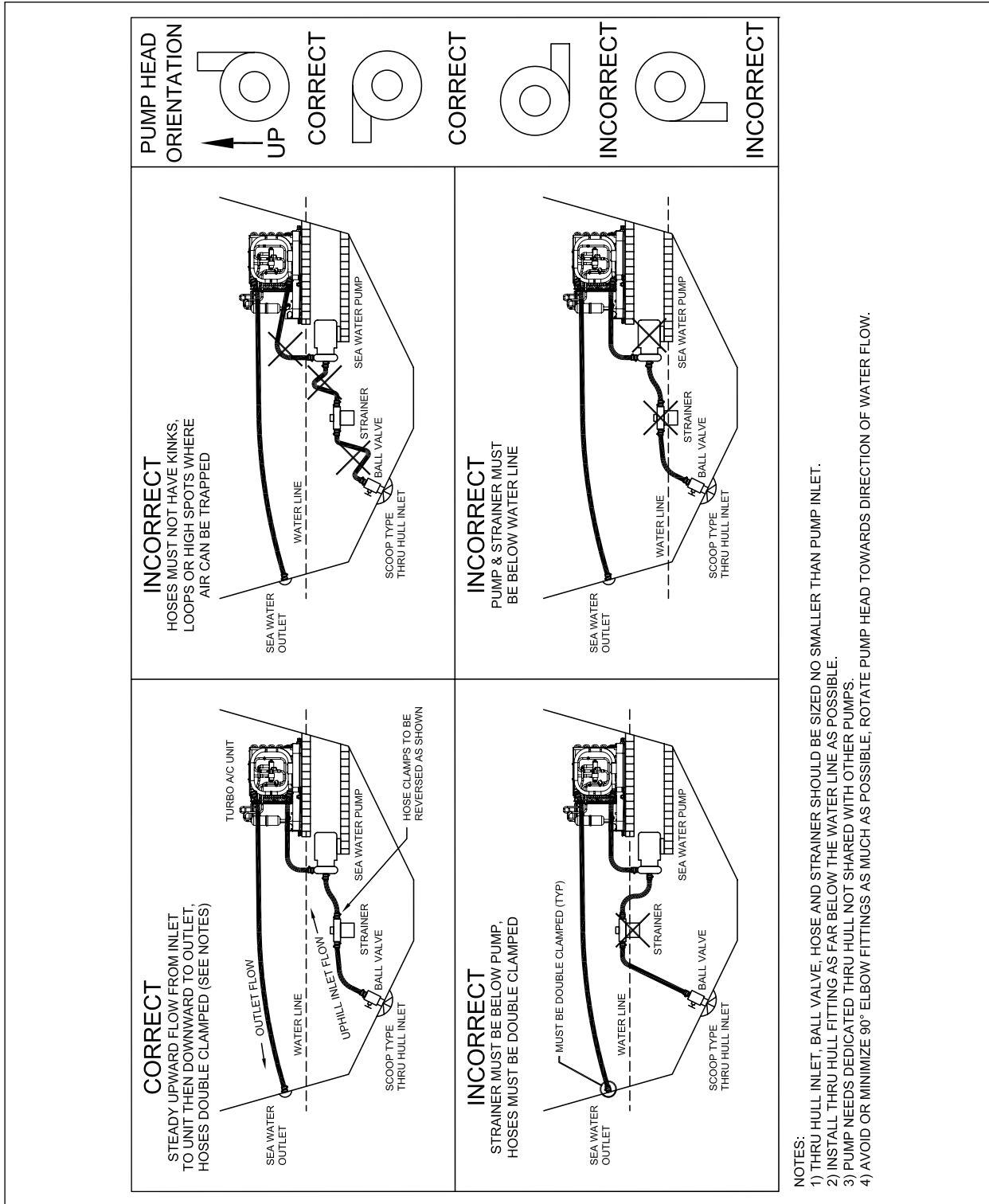

FIGURE 7. Seawater system

Dometic Turbo A/C Systems

Failure to do so will void warranty.

Electrical Connections, Grounding and Bonding

All a/c units have a terminal strip mounted inside the electric box. The terminal strip is labeled for proper connections of the electrical supply, ground wires and pump circuits. A wiring diagram is provided in the electrical box. The wiring diagram in the electrical box supersedes ABYC standards. The correct size circuit breaker should be used to protect the system as specified on the a/c unit's data plate label. A minimum of 12 AWG boat cable should be used to supply power to the a/c unit and the seawater pump. All connections shall be made with ring or captive fork terminals. **Turn off a/c power supply circuit breaker before opening electric box.**

Each a/c unit installed requires its own dedicated circuit breaker. If there is only one a/c unit installed, the seawater pump does not require a circuit breaker; the wiring from the seawater pump is connected to the terminal strip in the electric box. If two or more a/c units use the same seawater pump, the pump wires will be connected to a pump relay panel (PRP) which in turn has its own dedicated circuit breaker sized for the pump (20 amp max). Please see the wiring diagram furnished with the PRP (NOTE: PRP triac must have its mounting screw installed in order to dissipate heat). Electrical connections in the bilge and/or below the waterline should use heat shrink type butt splices.

Field wiring must comply with ABYC electrical codes. Power to the unit must be within the operating voltage range indicated on the data plate. Properly sized fuses or HACR circuit breakers must be installed for branch circuit protection. See data plate for maximum fuse/circuit breaker size (mfs) and minimum circuit ampacity (mca). All units must be effectively grounded to minimize the hazard of electrical shock and personal injury.

The following are to be observed:

1. AC (alternating current) grounding (green wire) must be provided with the AC power conductors and connected to the ground terminal (marked "GRND") at the AC power input terminal block of the unit(s), per

ABYC standard E-8, or equivalent.

2. Connections between the vessel's AC system grounding conductor (green wire) and the vessel's DC (Direct Current) negative or bonding system should be made as part of the vessel's wiring, per ABYC standard E-9, or equivalent.

3. When servicing or replacing existing equipment that contains a chassis-mounted ground stud, the service person or installer must check the vessel's wiring for the existence of the connection required in item 2 above.

ABYC standards are available from:

American Boat and Yacht Council
613 Third Street, Suite 10
Annapolis, MD 21403
Phone: (410) 990-4460
Fax: (410) 990-4466

The air conditioning unit must be connected to the boat's bonding system to prevent corrosion due to stray electrical current. Ensure that the AC ground of the air conditioning unit is properly connected to the AC ground of the boat. Within the boat itself, ensure that the AC ground bus is connected to the DC ground bus at exactly one place (no more, no less). All pumps, metallic valves and fittings in the seawater circuit that are isolated from the air conditioning unit by PVC or rubber hoses must be individually bonded to the boat's bonding system also. This will help eliminate any possibility of corrosion due to stray electrical current.

FAILURE TO PROPERLY GROUND AND BOND THE SYSTEM WILL VOID WARRANTY!

Installation Checklist & Final Inspection

(Review prior to and after installation.)

Note: Refer to the separate operation manual for installation and operation of controls.

Mounting

- Not in engine room or bilge areas, must be sealed away from exhaust or fumes
- Proper spacing allowed around unit
- Attached to solid level platform with hold down clips provided
- Condensate drain routed aft and down hill to a sealed sump (not bilge)
- Blower rotated toward supply air grill

Grills and Ducting

- Supply air grill mounted as high as possible
- Return air grill mounted as low and as close to the a/c unit as possible
- Return air grill mounted away from bilge vapors or exhaust fumes
- Ducting is pulled taut, straight, smooth and properly connected with no excess

Seawater System

- Seawater scoop located as far below the water line and as close to the keel as possible
- Shut off valve (sea cock) and speed scoop properly sealed and tight

Dometic Turbo A/C Systems

- Seawater pump is at least one foot below water line and securely mounted
- Strainer mounted below pump with access to filter
- Double/reversed stainless steel hose clamps on all hose connections below the water line
- Threaded seal tape on all threaded connections
- Hose runs uphill from speed scoop and sea cock to strainer, pump and a/c unit, then downhill (if possible) from a/c unit to overboard discharge
- Water flowing freely from overboard discharge while pump is running
- Pump relay panel, if used, must have its own circuit breaker sized for the pump (20 amp max)
- All metal fittings should be bonded

Electrical

- The wiring diagram is located in the electrical box. If that diagram is damaged or if you need a copy, please call Dometic with the unit part number, serial number, and wiring diagram number, all of which are located on the unit data plate.
- All butt connections on pumps wire tightly crimped and heat shrunk
- AC power source installed and grounded/bonded in accordance with ABYC standards
- Control wires connected to terminal strip with captive fork or ring terminals
- Circuit breakers sized according to specifications on the data plate label
- Digital display cable is connected at both ends
- Pump Relay Panel (if used) has a dedicated circuit breaker sized for the pump but not to exceed 20 amps maximum



Dometic Environmental Corporation

2000 N. ANDREWS AVE. EXT. | POMPANO BEACH, FL 33069 USA | 954-973-2477 | FAX 954 979 4414
P.O. BOX 15299 | RICHMOND, VA 23227 USA | 804-746-1313 | FAX 804-746-7248
www.DometicEnviro.com | sales@DometicEnviro.com

UNITED STATES & CANADA SERVICE ONLY

8:00 AM to 5:00 PM Eastern Time
MARINE AIR VECTOR TURBO A/C 954-973-2477
CRUISAIR STOWAWAY TURBO A/C 804-746-1313
24/7 A/C SERVICE HOTLINE: 5:00PM to 8:00 AM 888-440-4494

INTERNATIONAL SALES & SERVICE

EUROPE & MIDDLE EAST +44(0)870-330-6101
For all other areas visit our website to find your nearest distributor.