

HYGIENE & SANITATION

SXII SERIES SEAWATER SYSTEMS

For boats that require larger volumes of reliable water production, Dometic Sea Xchange SXII watermakers provide up to 2,200 GPD/8,328 LPD using reverse-osmosis technology to turn seawater into potable water.

EASY INSTALLATION

MODULAR OR COMPACT FRAME DESIGN

DURABLE

316SS COMPONENTS

POWERFUL

UP TO 2,200 GPD/8,328 LPD
OF FRESH WATER

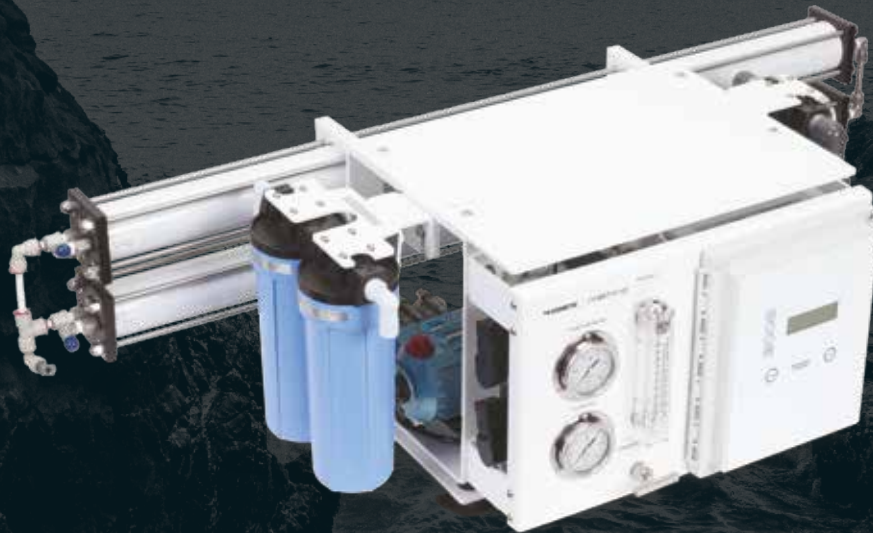

230V/60Hz
220V/50Hz

Mobile living made easy.

 **DOMETIC**

 **seaXchange**

STREAMLINED, COMPACT, HIGH-PERFORMANCE MEETS HIGH OUTPUT



Model	SXII 600	SXII 1200	SXII 1800	SXII 2200	Booster Pump	HP Pump
Capacity Per Hour (gal/l)	25/94.6	50/189.3	75/283.9	92/348.3	N/A	N/A
Capacity Per 24 Hours (gal/l)	600/2,271	1,200/4,542	1,800/6,814	2,200/8,328	N/A	N/A
Amps @ 230V/60Hz	14.0	14.0	14.0	14.0	3.6	10.4
Amps @ 220V/50Hz	15.4	15.4	15.4	15.4	4.4	11.0
Circuit Breaker Size	30 amps	30 amps	30 amps	30 amps	N/A	N/A
Membrane Quantity	1	2	3	4	N/A	N/A
Net Weight (lbs/kg) ²	127.6/57.9	142.2/64.5	157.2/71.3	174.2/79.0 ¹	N/A	N/A
Shipping Weight (lbs/kg) ²	207.5/94.1	232.2/105.3	257.2/116.6	284.2/128.9	N/A	N/A
Shipping Dimensions (H x W x D) ²	31 x 41.5 x 48.5 in. / 762 x 1,055 x 1,232 mm				N/A	N/A

¹ Combined weight of system and remote-mounted membrane vessel assembly. System weight is 112.1 lbs/50.8 kg; membrane vessel assembly weight is 62.1 lbs/28.2 kg.

² Includes booster pump and HP pump.

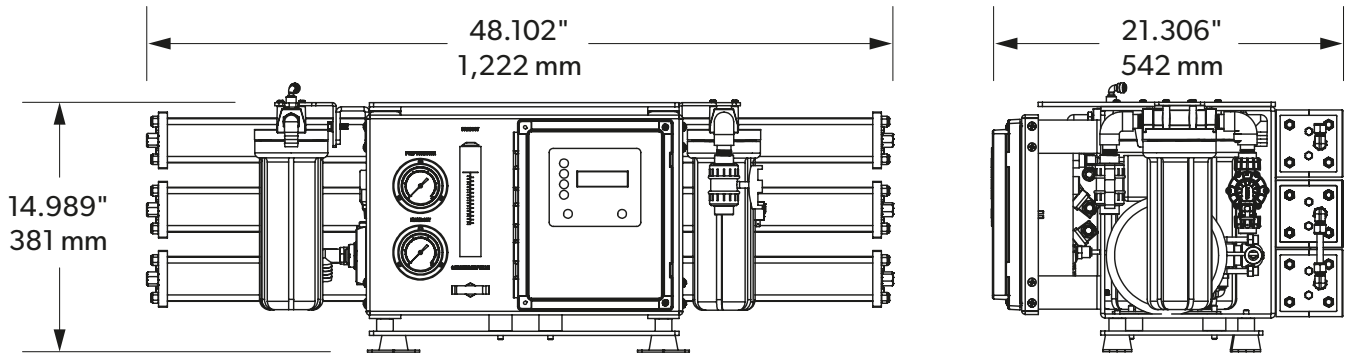

1. EASY TO USE

Integrated pressure gauges, flow meter, and control panel with backlit display



2. LESS NOISE

Vibration-isolation mounts reduce noise and vibration



3. RELIABILITY

Durable booster pump with 316SS motor shaft